



Series W



Cone Drive Operations, Inc.
240 East 12th Street
Traverse City, MI 49684, USA

T +1 888 994 2663
E orders@conedrive.com
W www.conedrive.com



ACCUDRIVE PRECISION PRODUCTS

Now you can get design flexibility and lasting performance from our complete family of AccuDrive Precision Products.

Model RG Right Angle Gearhead

Output torque capacity up to 8,500 lb.in.
Motor sizes (standard), adapters to fit servo motors, NEMA and IEC
Center distance 1.5 to 3.5 inches
Input power ratings up to 27 H.P, speed range up to 4,000 RPM
Sizes available 15, 20, 25, 30 and 35
Universal Mounting with shaft mount and flange mount standard
in single reduction type
Gear ratios from 5:1 to 60:1



Series S Servo Gearhead

Economical Servo Solution
Output torque up to 7,540 lb.In.
Motor adapters to fit servo motors
Center distance from 1.33 inch up to 3.54 inch
Speed range up to 4,000 RPM
Flexible mounting (hollow output standard with plug in solid shaft)
Ratios from 5:1 to 60:1



Series P In-line Planetary Servo Gearhead

Output torque capacity up to 21,240 lb.in. (2,400 Nm)
Speed range up to 6,000 RPM input.
Sizes available 42, 60, 90, 120, 140, 180, 220 (S-Type)
Sizes available 60, 75, 100, 140, 180, 210, 240 (P-Type)
Gear ratios from 3:1 to 100:1 available from stock (S-Type & P-T)
Universal Mounting with shaft mount and flange mount standard.
Three arcminutes backlash or better.



Series E & LE In-line Planetary Servo Gearhead

Output torque capacity up to 7,080 lb.in.
Speed range up to 6,000 RPM input.
Sizes 40, 60, 90, 115, 512 and 160 (Series E)
Gear ratios from 3:1 to 64:1 (Series E)
Sizes 50, 70, 90, 120, 155, 205, 235 (Series LE)
Gear ratios from 3:1 to 100:1 (Series LE)
Universal Mounting with shaft mount and flange mount standard.
Backlash as low as eight arcminutes (Series E) and five arcminutes (Series LE)



ABSOLUTE ZERO Backlash AccuDrive Gearing

Unique design captures both sides of the gear tooth to completely eliminate backlash. Automatically compensates for wear-guaranteed zero backlash for the life of the gearset. Available for single, double and triple reduction types, gear sets, special designs and the Series W.



Three Levels of Precision

- Zero Backlash - absolute zero backlash for life
- Low Backlash - as low as 3 arcminutes
- Standard Backlash - long lasting ruggedness for less demanding applications

Anodized Aluminium Universal Housing

- Compact cube design saves space
- Machined pilots on output shaft caps
- Universal housing mounts in any orientation
- Lightweight aluminium reduces weight

Hollow Shaft Standard

- Compact mounting saves space
- No coupling required saves cost
- Zero backlash shrink disc hollow shaft option
- Single and double oil extended solid shafts provide mounting flexibility

Maintenance Free

- Factory filled with synthetic gear oil
- No lubrication service throughout unit life
- Anodized housing, double oil seals and O-rings provide IP65 protection, ensure worry-free operation and protection against harsh environments

Cone Drive Gearing

- High torque capacity
- High efficiency
- Quiet and smooth running
- Exact ratios 5:1 and 60:1 in a single stage
- High torsional rigidity

Easy Motor Mounting

- Integrated zero backlash belows coupling provides fast, error-free alignment
- Integrated motor flange mounts directly to your servomotor, NEMA motor, or IEC motor

Free Series W

Application Assistance

To ensure optimum performance, our Application Engineers can help you design the ideal servo mechanical drive system for your particular application.

We're available to further discuss the Model RG design characteristics and help with specifying backlash, gear ratios, and speeds.

Call and tell us about your application

Call us Toll free at 888-994-2663



Our AccuMate® program can help you select the right servo gearhead for your application.

Visit <http://www.conetools.com/Accudrive> to start using AccuMate®.

CONEDRIVE™
GEARING SOLUTIONS

Contact Us | Cone Drive | Cone Tools

Welcome to Cone Drive's selection and drawing download page
Our servo rated range of AccuDrive™ products include the Series W, Model RG and Series S right angle and Series P and E planetary configurations. The Product Selection Tool will help you select, generate a catalog part number for ordering and drawing for any three of our right angle gearheads. The Drawing Download Tool is for the user who already knows their catalog number and simply needs to download a drawing.

AccuMate® Selection Tool

Step 3: Series W Selected

Series Selection Summary (Based on Step 2 of Series)

Series	Ratio
W06-006	1.00
W06-009	1.25
W06-015	1.50
W06-020	1.75
W06-030	2.00

Series Selection Summary (Based on Step 2 of Series)

Series	Ratio
W06-006	1.00
W06-009	1.25
W06-015	1.50
W06-020	1.75
W06-030	2.00

For guided product selection click here

Drawing Download Tool

W064015.SSA903DHLDK- [Configure]

Click here to register and download drawing file

Click here if you know the part number and want a 2-D drawing or 3-D model

© Copyright 2007 Cone Drive Operations, Inc. All Rights Reserved

Table of contents

» Unit Designation	4
» Motor Mounting Codes.....	5
» Standard And Low Backlash Specification	6
» Sizing And Selection Verification	8
» Zero Backlash Design	9
» Standard Hollow Shaft Dimensions	10
» Optional Solid Shaft Dimensions.....	11
» Servo Gearhead Optional Shrink Disc Hollow Shaft and Shaft End Mount Dimensions	12
» Servo Gearhead Expanding Rating Table.....	13
» Installation, Operation & Maintenance Instructions.....	18

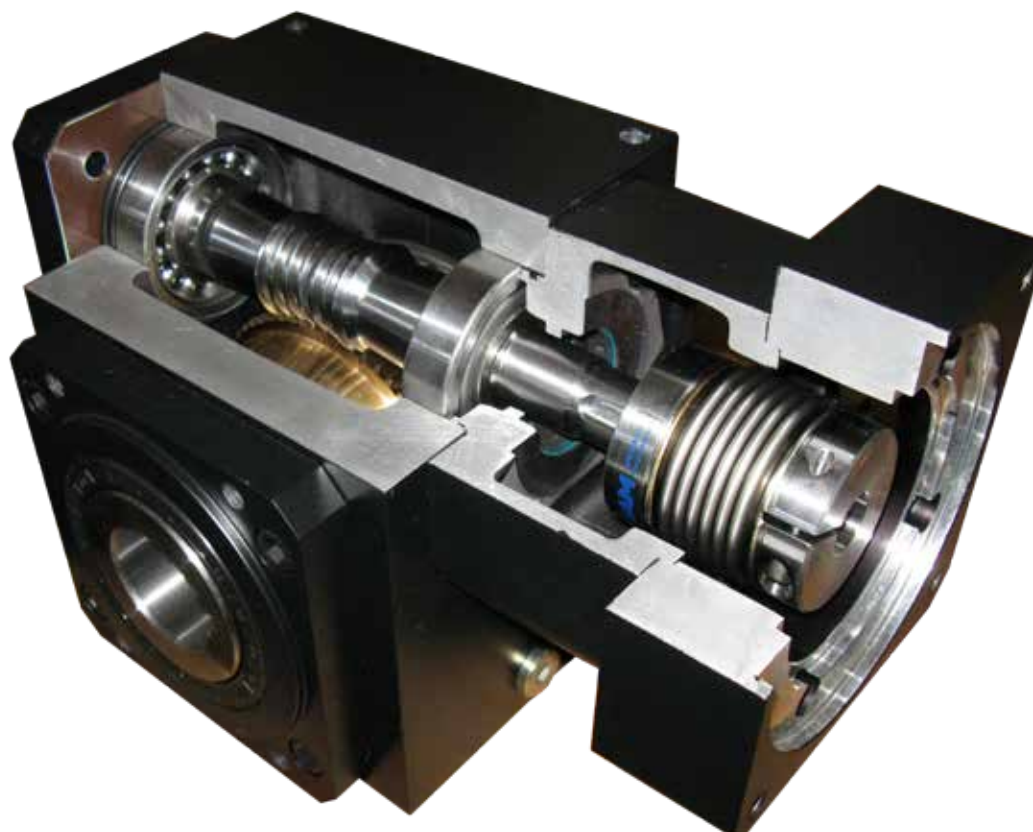

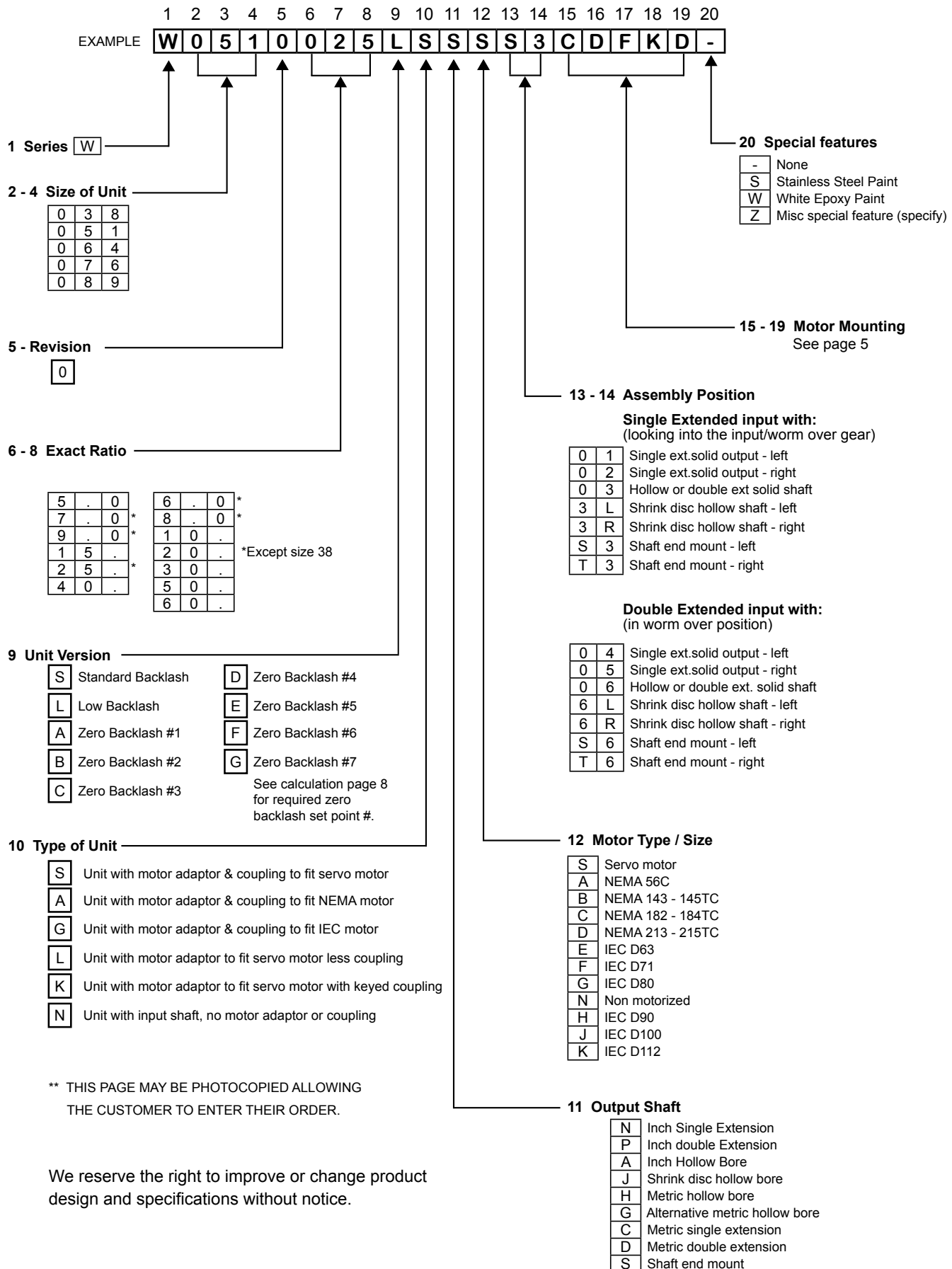

Series W

Motor Mounting Codes

Servo Motor Flange Selection

1. Go to the appropriate table for the unit size you have selected.
2. Select the appropriate codes for columns 15 - 19 to match the dimensions on your servo motor flange.
3. Make sure your motor length fits the range accommodated by flange square for the size unit you're specifying.
4. If you can't locate the appropriate code for your motor or need assistance, please contact us.

W38 & W51

Motor Flange Square

Column 15 Entry	Flange Square (mm)		90		115		130		140	NEMA or IEC
	Acceptable Motor Shaft Length		22 - 45	46 - 65	22 - 39	40 - 65	40 - 47	48 - 73	48 - 73	
	Unit Size	W38 & W51	B	M	C	D	E	F	G	

Motor Pilot Diameter

Column 16 Entry	Motor Pilot Diameter (mm)												NEMA or IEC
	38.15	40	50	55.55	60	70	73.07	80	95	110	114.3	130	
	A	B	C	N	D	E	F	G	H	J	K	L	

Bolt Circle Diameter

Column 17 Entry	Bolt Circle Diameter (mm)																NEMA or IEC	
	63	65	66.68	70	75	80	85	90	95	98.43	100	115	125.73	130	145	149		165
	A	B	C	D	E	F	U	G	H	J	K	L	T	M	N	P		Q

Motor Mounting Bolt Size

Column 18 Entry	Motor Flange Thru Hole Size	4.5 - 5.2		5.3 - 6.3		6.4 - 8.3		8.4 - 10.3		10.4 - 12.4		12.5 - 15.0		NEMA or IEC
		A	B	C	D	E	F	G	H	I	J	K		
	Motor Flange Tapped Holes	M4	M5	M6	M8	M10	M12	1/4 - 20	3/8 - 16	1/2 - 13	NEMA or IEC			

Motor Shaft Diameter

Column 19 Entry	Motor Shaft Diameter (mm)														NEMA or IEC
	9.525	11	12	12.7	14	15.875	16	19	19.05	22	22.225	24	25.4	28	
	B	D	E	F	G	H	J	K	L	M	N	P	Q	R	

W64, W76 & W89

Motor Flange Square

Column 15 Entry	Flange Square (mm)		115		140		190		NEMA or IEC
	Acceptable Motor Shaft Length		20-32	33-60	38-68	69-89	38-68	58-87	
	Unit Size	W64, W76 & W89	C	D	G	H	K	L	

Motor Pilot Diameter

Column 16 Entry	Motor Pilot Diameter (mm)						NEMA or IEC
	80	95	110	114.3	130	180	
	G	H	J	K	L	M	

Bolt Circle Diameter

Column 17 Entry	Bolt Circle Diameter (mm)								NEMA or IEC
	100	115	130	145	149.23	165	200	215	
	K	L	M	N	P	Q	R	S	

Motor Mounting Bolt Size

Column 18 Entry	Motor Flange Thru Hole Size	6.4 - 8.3		8.4 - 10.3		10.4 - 12.4		12.5 - 15.0		NEMA or IEC
		C	D	E	F	G	H			
	Motor Flange Tapped Holes	M6	M8	M10	M12	1/4 - 20	3/8 - 16	1/2 - 13	Q	

Motor Shaft Diameter

Column 19 Entry	Motor Shaft Diameter (mm)																NEMA or IEC	
	14	15.875	16	19	19.05	22	22.225	24	25.4	28	28.575	31.75	32	34.925	35	38*		42*
	G	H	J	K	L	M	N	P	Q	R	S	T	U	V	W	X		Y

*Size 89 ONLY

Standard and Low Backlash Specifications

	Ratios	Efficiency		Size				
				W38	W51	W64	W76	W89
Output Torque ⁽¹⁾ T _{ACCEL}	5	92%	lb.In.	410	800	1470	2430	4250
			Nm	46	90	170	270	480
	6	91%	lb.In.		880	1630	2710	4750
			Nm		99	180	310	540
	7	91%	lb.In.		930	1720	2870	5030
			Nm		110	190	320	570
	8	91%	lb.In.		980	1820	3050	5340
			Nm		110	210	340	600
	9	90%	lb.In.		1000	1850	3140	5480
			Nm		110	210	350	620
	10	90%	lb.In.	520	1020	1900	3240	5650
			Nm	59	120	210	370	640
	15	88%	lb.In.	540	1060	1960	3370	5870
			Nm	61	120	220	380	660
	20	85%	lb.In.	530	1060	1920	3300	5740
			Nm	60	120	220	370	650
	25	84%	lb.In.		1020	1920	3300	5740
			Nm		120	220	370	650
	30 ⁽³⁾	80%	lb.In.	500	990	1840	3160	5510
			Nm	56	110	210	360	620
40 ⁽³⁾	76%	lb.In.	460	940	1750	3020	5250	
		Nm	52	110	200	340	590	
50 ⁽³⁾	73%	lb.In.	460	910	1690	2910	5060	
		Nm	52	100	190	330	570	
60 ⁽³⁾	70%	lb.In.	420	870	1620	2790	4850	
		Nm	47	100	180	320	550	

		Size				
		W38	W51	W64	W76	W89
Emergency Stop		(3 - Times T _{Run})				
Maximum Radial Load ⁽²⁾	lbs.	700	1500	2000	2500	3500
	N	3110	6670	8890	11110	15560
Maximum Axial Load	lbs.	400	410	420	950	900
	N	1780	1820	1860	4220	4000
Average Lifetime	Hours.	25,000				
Weight	lbs.	9	18	32	56	110
	kg	4.1	8.2	14.5	25.4	49.9
Operating Temperature	°F	(-13 to +210)				
	°C	(-25 to +100)				
Degree of Protection		IP 65				
Lubrication		Synthetic SHC 634 gear oil				
Mounting Position		any				

Key: 1) These values are based on an input speed of 2000 rpm. For all input speeds and continuous run output torque rating, see pages 13 - 17 for expanded rating tables.

2) Half way along the output and 100% duty cycle.

3) Ratios 30:1 and above can be self-locking. It is important to review the input torque applied during stopping and reversing. This is of particular importance when unrestrained high inertia loads are involved. Please contact our sales department to review your application.

Series W

Standard and Low Backlash Specifications

	Ratios		Size				
			W38	W51	W64	W76	W89
Moment of Inertia ⁽¹⁾ J _{gear}	5	lb.in. S ² 10 ⁻⁴	11.10	20.40	74.20	127.00	220.00
		kgcm ²	1.26	2.31	8.38	14.40	24.80
	6	lb.in. S ² 10 ⁻⁴		18.60	69.20	111.00	180.00
		kgcm ²		2.10	7.82	12.50	23.30
	7	lb.in. S ² 10 ⁻⁴		17.50	66.00	100.00	156.00
		kgcm ²		1.97	7.45	11.30	17.60
	8	lb.in. S ² 10 ⁻⁴		16.80	64.30	93.90	140.00
		kgcm ²		1.90	7.26	10.60	15.80
	9	lb.in. S ² 10 ⁻⁴		16.30	63.00	89.40	129.00
		kgcm ²		1.84	7.11	10.10	14.60
	10	lb.in. S ² 10 ⁻⁴	9.66	15.90	62.00	86.20	122.00
		kgcm ²	1.09	1.80	7.00	9.73	13.80
	15	lb.in. S ² 10 ⁻⁴	9.38	15.10	59.80	78.50	104.00
		kgcm ²	1.06	1.71	6.75	8.87	11.70
	20	lb.in. S ² 10 ⁻⁴	9.30	1.48	59.80	78.50	104.00
		kgcm ²	1.05	1.67	6.67	8.57	11.00
	25	lb.in. S ² 10 ⁻⁴		14.70	58.70	74.60	94.40
		kgcm ²		1.66	6.62	8.43	10.70
	30	lb.in. S ² 10 ⁻⁴	9.22	14.60	58.40	74.00	92.70
		kgcm ²	1.04	1.65	6.60	8.35	10.50
40	lb.in. S ² 10 ⁻⁴	9.20	14.60	58.30	73.30	91.20	
	kgcm ²	1.40	1.64	6.58	8.28	10.30	
50	lb.in. S ² 10 ⁻⁴	9.20	14.50	58.20	73.00	90.40	
	kgcm ²	1.04	1.64	6.57	8.24	10.20	
60	lb.in. S ² 10 ⁻⁴	9.20	14.50	58.10	72.80	90.00	
	kgcm ²	1.04	1.64	6.56	8.22	10.20	

			Size				
			W38	W51	W64	W76	W89
Nominal Backlash	Zero	arcmin.		0	0	0	0
	Low	arcmin.	8	6	5	4	3
	Standard	arcmin.	24	15	12	10	10
Torsional Rigidity		lb.in./min	34	67	155	341	628
		Nm/min	3.8	7.6	17.5	38.5	71
Max. cyclic input speed ⁽²⁾ ⁽⁴⁾		rpm	6000	6000	6000	6000	6000
Max. cyclic input speed ⁽³⁾ ⁽⁴⁾		rpm	4000	4000	4000	4000	4000

Key: (1) The moment of inertia refers to the input shaft and includes coupling.

(2) Maximum input speed allowed for short acceleration cycles.

(3) Maximum input speed allowed for continuous or longer duration acceleration cycles.

(4) Higher input speeds may be acceptable. Please contact our Application Engineers to review your application.

Conversion Table

Metric	Inch
1 mm	0.0394 in.
1 N	0.225 lb.
1 kg	2.205 lb.
1 Nm	8.85 in.lb.
1kgcm ²	8.85 x 10 ⁻⁴ lb.in.S ²

Required Application Data

Motor continuous Torque	T_{cont}
Motor peak Torque	T_{peak}
Motor Rotor Inertia*	J_{mot}
Gearhead Inertia*	J_{gear}
Load Inertia	J_{load}
Load Torque (non-dynamic Frictional and/or Gravity Load)	T_{load}

Reduction Ratio

Cycles per Hour	C_{hr}
Hours per Day	D_{hr}
Required Output Torque	T_{req}
Maximum Input Speed	S_{peak}

*Any unit can be used for inertia as long as it is used consistently.
If you need assistance please contact our Application Engineers.

Calculated Data

Input torque: $T_{input} = T_{load} / (\text{Ratio} \times \text{eff.})$
Load inertia referred to input shaft*:
 $J_{ref} = J_{load} / \text{Ratio}^2 + J_{gear}$

*See page 7 for J_{gear}

Efficiency (Eff.)		
Ratio 5:1 = .92	Ratio 10 :1 = .90	Ratio 40 :1 = .76
Ratio 6:1 = .91	Ratio 15 :1 = .88	Ratio 50 :1 = .73
Ratio 7:1 = .91	Ratio 20 :1 = .85	Ratio 60 :1 = .70
Ratio 8:1 = .91	Ratio 25 :1 = .84	
Ratio 9:1 = .90	Ratio 30 :1 = .80	

Cycles per Hour:

C_{hr}	C_f	C_{hr}	C_f	Hours per Day:	D_{hr}	D_f
0 - 500	.80	3,000	1.50	1 - 2	.80	
1,000	1.00	5,000	2.00	3 - 8	1.00	
2,000	1.25	10,000	2.30	8 - 12	1.50	
				12+	1.50	

data example:

$T_{cont} = 10.9 \text{ Nm}$	$J_{gear} = 0.2$	Ratio = 10
$T_{peak} = 45.7 \text{ Nm}$	$J_{load} = 10$	$C_{hr} = 1000$
$T_{req} = 80 \text{ Nm}$	$T_{load} = 10$	$D_{hr} = 8$
$J_{mot} = 1.0$		Speed = 3000 rpm

Gearhead Selection

For Cyclical Applications

Calculate service factor: Sf

$$Sf = T_{accel} / (T_{reg} \times C_f)$$

$$*W51 T_{accel} @3000 \text{ rpm} = 99\text{Nm}$$

$$Sf = 99 / (80 \times 1.0) = 1.24$$

*Select gearhead size and rated output torque T_{accel} based on the peak motor speed used in your application from the rating table, page 13 - 17.

Minimum Sf:	Standard backlash = 1.0
	Low backlash = 1.2
	Zero backlash = 2.0

for Continuous Applications

Calculate service factor: Sf

$$Sf = T_{run} / (T_{reg} \times D_f)$$

$$*W64 T_{run} @3000 \text{ rpm} = 130\text{Nm}$$

$$Sf = 130 / (80 \times 1.0) = 1.63$$

*Select gearhead size and rated output torque T_{run} based on the continuous motor speed used in your application from the rating table, page 13 - 17.

Minimum Sf:	Standard backlash = 1.0
	Low backlash = 1.2
	Zero backlash = 2.0

Motor Verification

Steps:

One - Calculate the inertia parameter: J_{par}

$$J_{par} = J_{mot} / (J_{ref} + J_{mot})$$

Two - Calculate the maximum gearhead

output torque: T_{output}

$$T_{output} = ((T_{peak} - T_{input}) \times (1 - J_{par}) + T_{input}) \times \text{Ratio} \times \text{Eff.}$$

Three - Calculate the motor capacity: M_{cap}

$$M_{cap} = T_{output} / T_{req}$$

Minimum M_{cap} : Standard backlash = 1.0

Low backlash = 1.0

Zero backlash = refer to set point chart on page 9

applied calculation example:

$$J_{ref} = 10 / 10^2 + .2 = .3$$

$$J_{par} = 1 / (.3 + 1) = .77$$

$$T_{input} = 15 / (10 \times .9) = 1.67$$

$$T_{output} = ((45.7 - 1.67) \times (1 - .77) + 1.67) \times 10 \times .9 = 106 \text{ Nm}$$

$$M_{cap} = 106 / 80 = 1.32$$

Series W

Zero Backlash Design

The AccuDrive Series W zero backlash units achieve zero backlash by applying a firm, yet moveable clamping force to both sides of the gear teeth. The clamping force is set based on the output torque required for your application.

Series W zero backlash units also include a new patented (Pat. 6,386,059) external adjustment feature that allows the clamping force to be easily optimized or adjusted if the requirements of your application change.

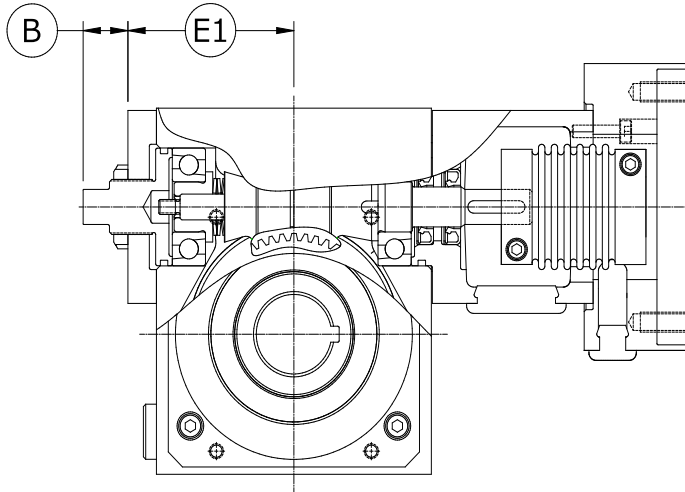

Zero Backlash Features

- Self-compensating design maintains zero backlash for life
- Factory set based on output torque required for your application
- External adjustment maximizes operating efficiency.

Dimensions	Unit Size			
	W51	W64	W76	W89
ⓑ mm(max)	22	22	32	35
ⓔ1 mm	71	96	111	131

Product Specifications

- Available in size 51,64 76 & 89 only
- Single extended input only
- Maximum input speed 3,000 rpm
- All other specifications and dimensions remain the same.

Zero Backlash Output Torque Setpoints

1 Use the Series W gearhead selection formula and motor verification on page 8 to select the appropriate size gearhead for your application.

2 Select the closest zero backlash setpoint number where the output torque for the size unit you have selected exceeds the required output torque (T_{req}) for your application.

3. Make sure the motor capacity (M_{cap}) calculated in step 3 on page 8, exceeds the required motor capacity for the zero backlash setpoint required for your application.

4. Use the setpoint number to select the appropriate Series W unit designation code in column 9, on pages 4 and 5.

Zero Backlash setpoint #	Output Torque								Min Motor Capacity (M_{cap})
	W51		W64		W76		W89		
	lb.in	Nm	lb.in	Nm	lb.in	Nm	lb.in	Nm	
1	83	9	81	9	218	25	202	23	1.20
2	102	12	124	14	272	31	448	51	1.30
3	147	17	206	23	301	34	694	78	1.30
4	245	28	255	29	350	40	1075	121	1.30
5	374	42	399	45	770	87	1737	196	1.50
6	490	55	666	75	1237	140	2470	279	1.75
7	612	69	952	108	1695	275	3094	350	2.00

Standard Hollow Shaft Dimensions

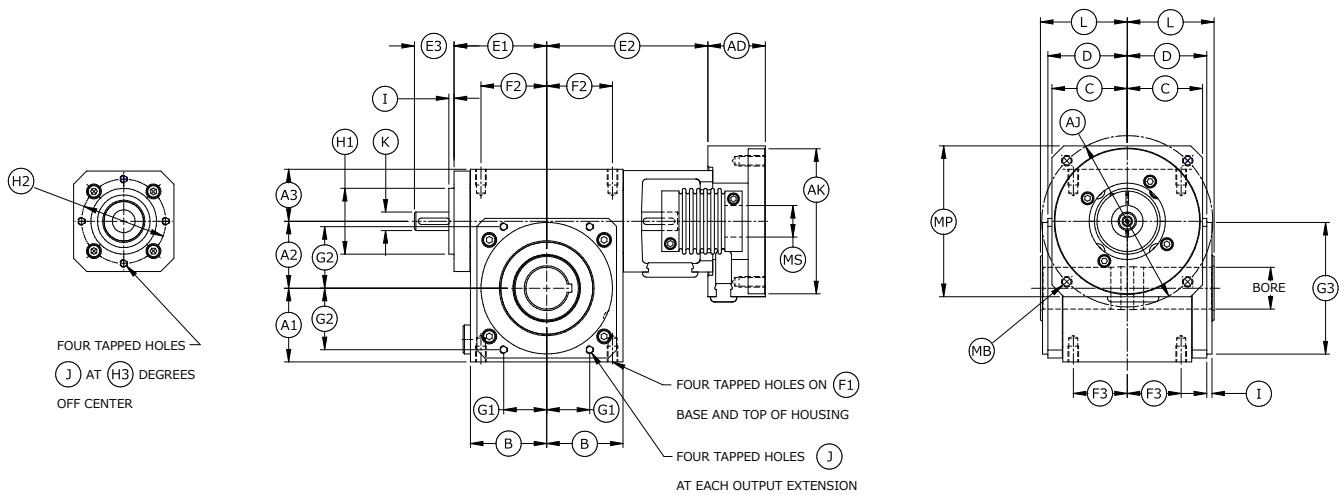

Standard Hollow Shaft units

Size	A1		A2 (CD)		A3		B		C		D		E1	
	inch	mm	inch	mm	inch	mm	inch	mm	inch	mm	inch	mm	inch	mm
38	1.772	45	1.500	38.1	1.378	35.0	1.988	50.5	1.535	39.0	2.004	50.9	2.484	63.1
51	2.205	56	2.000	50.8	1.555	39.5	2.283	58.0	1.929	49.0	2.378	60.4	2.732	69.4
64	2.874	73	2.500	63.5	1.752	44.5	3.110	79.0	2.126	54.0	2.752	69.9	3.697	93.9
76	3.228	82	3.000	76.2	2.197	55.8	3.524	89.5	2.894	73.5	3.697	93.9	4.327	109.9
89	3.937	100	3.500	88.9	2.484	63.1	4.134	105	3.543	90.0	4.382	111.3	4.937	125.4

Size	E2		E3		F1	F2		F3		G1		G2		G3	
	inch	mm	inch	mm	tap	inch	mm	inch	mm	inch	mm	inch	mm	inch	mm
38	4.520	114.80	1.189	30.2	M8	1.654	42.0	1.260	32	0.721	18.31	1.356	34.43	2.520	64 h8
51	4.815	122.30	1.224	31.1	M8	1.969	50.0	1.614	41	1.287	32.69	1.838	46.69	3.937	100 h8
64	5.986	152.00	1.461	37.1	M8	2.697	68.5	1.732	44	1.581	40.15	2.257	57.34	4.724	120 h8
76	6.478	164.55	1.323	33.6	M10	3.110	79.0	2.480	63	1.785	45.34	2.548	64.73	5.276	134 h8
89	7.795	198.00	2.031	51.6	M10	3.740	95.0	3.150	80	1.831	46.50	3.171	80.54	5.709	145 h8

Size	H1		H2		H3	I		J	K			L	
	inch	mm	inch	mm	dgrs.	inch	mm	tap	inch	mm	keyway	inch	mm
38	1.811	46 h8	2.205	56	0	0.157	4	M6	0.551	14 k6	5 x 2.3 x 25	2.205	56
51	1.969	50 h8	2.520	64	0	0.157	4	M6	0.551	14 k6	5 x 2.3 x 24	2.598	66
64	2.362	60 h8	3.071	78	25	0.157	4	M8	0.748	19 k6	6 x 2.8 x 25	2.913	74
76	2.756	70 h8	3.622	92	25	0.157	4	M10	0.945	24 k6	8 x 3 x 28	3.937	100
89	3.543	90 h8	4.331	110	25	0.157	4	M10	1.102	28 k6	8 x 4 x 40	4.606	117

Size	Inch Bore			Metric Bore			Alternative Metric Bore			AD Max.		AK	AJ	MP	MB	MS
	inch	tol.	mm	inch	tol.	mm	inch	tol.	mm	tap	mm					
38	0.8754	+/- .0004	3/16 x 3/32	25	H7	8 x 3.3	22	H9	6 x 2.8	2.055	52.2	Motor Plate Dimensions are made to fit your servo motor. Refer to Page 5 for available dimensions.				
51	1.2505	+/- .0005	1/4 x 1/8	30	H7	8 x 3.3	-	-	-	2.055	52.2					
64	1.6880	+/- .0005	3/8 x 3/16	35	H7	10 x 3.3	38	H9	10 x 3.3	2.717	69.0					
76	1.9380	+/- .0005	1/2 x 1/4	45	H7	14 x 3.8	48	H9	14 x 3.8	2.717	69.0					
89	2.4380	+/- .0005	5/8 x 5/16	60	H7	18 x 4.4	-	-	-	2.717	69.0					

Series W

Optional Solid Shaft Dimensions

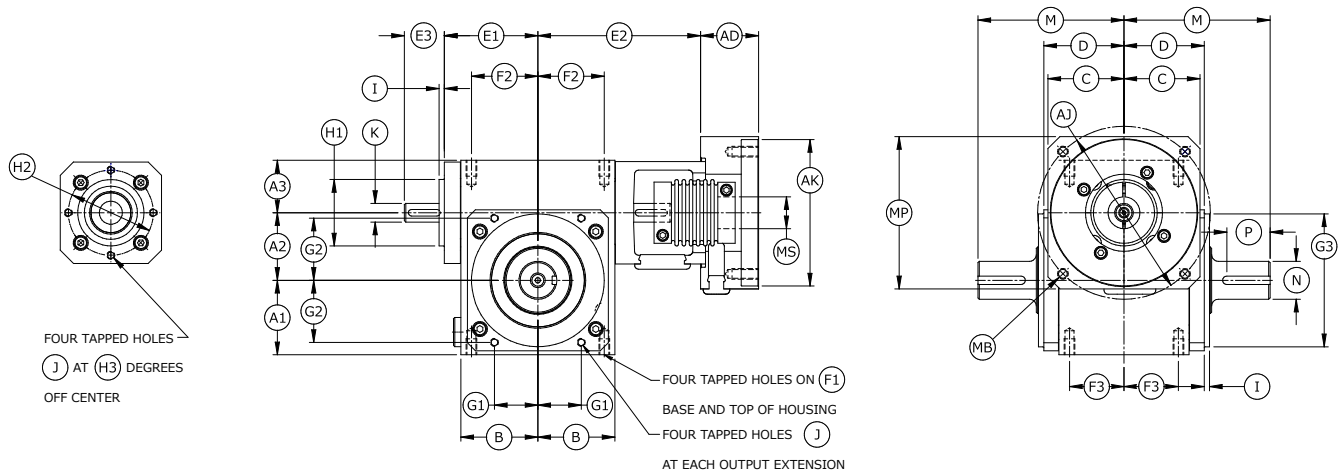

Optional Solid Shaft units

Size	A1		A2 (CD)		A3		B		C		D		E1	
	inch	mm	inch	mm	inch	mm	inch	mm	inch	mm	inch	mm	inch	mm
38	1.772	45	1.500	38.1	1.378	35.0	1.988	50.5	1.535	39.0	2.004	50.9	2.484	63.1
51	2.205	56	2.000	50.8	1.555	39.5	2.283	58.0	1.929	49.0	2.378	60.4	2.732	69.4
64	2.874	73	2.500	63.5	1.752	44.5	3.110	79.0	2.126	54.0	2.752	69.9	3.697	93.9
76	3.228	82	3.000	76.2	2.197	55.8	3.524	89.5	2.894	73.5	3.697	93.9	4.327	109.9
89	3.937	100	3.500	88.9	2.484	63.1	4.134	105	3.543	90.0	4.382	111.3	4.937	125.4

Size	E2		E3		F1	F2		F3		G1		G2		G3	
	inch	mm	inch	mm	tap	inch	mm	inch	mm	inch	mm	inch	mm	inch	mm
38	4.520	114.80	1.189	30.2	M8	1.654	42.0	1.260	32	0.721	18.31	1.356	34.43	2.520	64 h8
51	4.815	122.30	1.224	31.1	M8	1.969	50.0	1.614	41	1.287	32.69	1.838	46.69	3.937	100 h8
64	5.986	152.00	1.461	37.1	M8	2.697	68.5	1.732	44	1.581	40.15	2.257	57.34	4.724	120 h8
76	6.478	164.55	1.323	33.6	M10	3.110	79.0	2.480	63	1.785	45.34	2.548	64.73	5.276	134 h8
89	7.795	198.00	2.031	51.6	M10	3.740	95.0	3.150	80	1.831	46.50	3.171	80.54	5.709	145 h8

Size	H1		H2		H3	I		J	K			M	
	inch	mm	inch	mm	dgrs.	inch	mm	tap	inch	mm	keyway	inch	mm
38	1.811	46 h8	2.205	56	0	0.157	4	M6	0.551	14 k6	5 x 2.3 x 25	3.386	86
51	1.969	50 h8	2.520	64	0	0.157	4	M6	0.551	14 k6	5 x 2.3 x 24	4.331	110
64	2.362	60 h8	3.071	78	25	0.157	4	M8	0.748	19 k6	6 x 2.8 x 25	4.882	124
76	2.756	70 h8	3.622	92	25	0.157	4	M10	0.945	24 k6	8 x 3 x 28	6.417	164
89	3.543	90 h8	4.331	110	25	0.157	4	M10	1.102	28 k6	8 x 4 x 40	7.874	200

Size	N (Inch)		P (Inch)		N (mm)			P (mm)*			AD Max.		AK	AJ	MP	MB	MS
	inch	tol.	keyway	length	mm	tol.	keyway	inch	length	ofst.	Inch	mm					
38	0.7497	+/- .0003	3/16 x 3/32	26	20	k6	6 x 3.5	22	22	4	2.055	52.2	Motor Plate Dimensions are made to fit your servo motor. Refer to Page 5 for available dimensions.				
51	1.1247	+/- .0003	1/4 x 1/8	38	25	k6	8 x 4	36	36	4	2.055	52.2					
64	1.2497	+/- .0003	1/4 x 1/8	40	30	k6	8 x 4	40	40	4	2.717	69.0					
76	1.4997	+/- .0003	3/8 x 3/16	45	35	k6	10 x 5	50	50	5	2.717	69.0					
89	1.8747	+/- .0003	1/2 x 1/4	60	45	k6	14 x 5.5	63	63	5	2.717	69.0					

Servo Gearhead Optional Shrink Disc Hollow Shaft and Shaft End Mount Dimensions

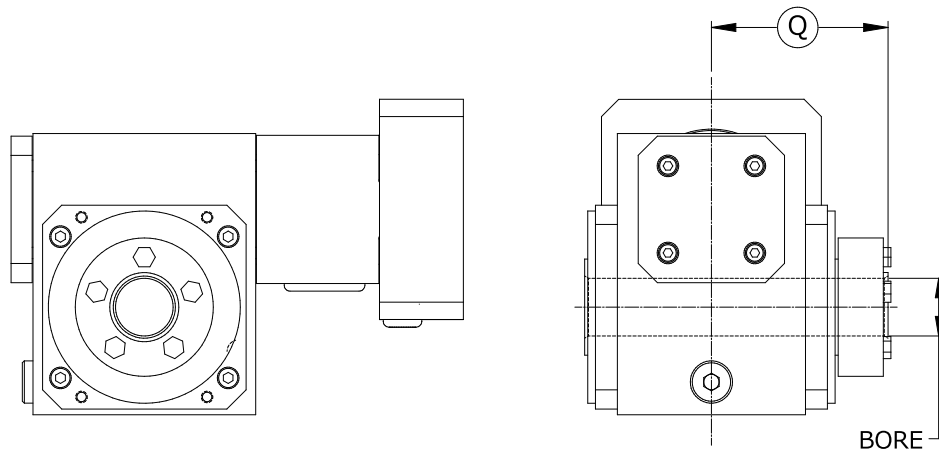

Optional Shrink Disc Hollow Shaft

Size	Q		BORE (mm)		Customer Mating Shaft Diameter		
	inch	mm	mm	+/-	mm	+	-
38	3.15	80	25.005	0.005	25	0	0.010
51	3.62	92	30.005	0.005	30	0	0.010
64	4.29	109	35.008	0.008	35	0	0.016
76	5.32	135	45.008	0.008	45	0	0.016
89	6.06	154	60.010	0.010	60	0	0.020

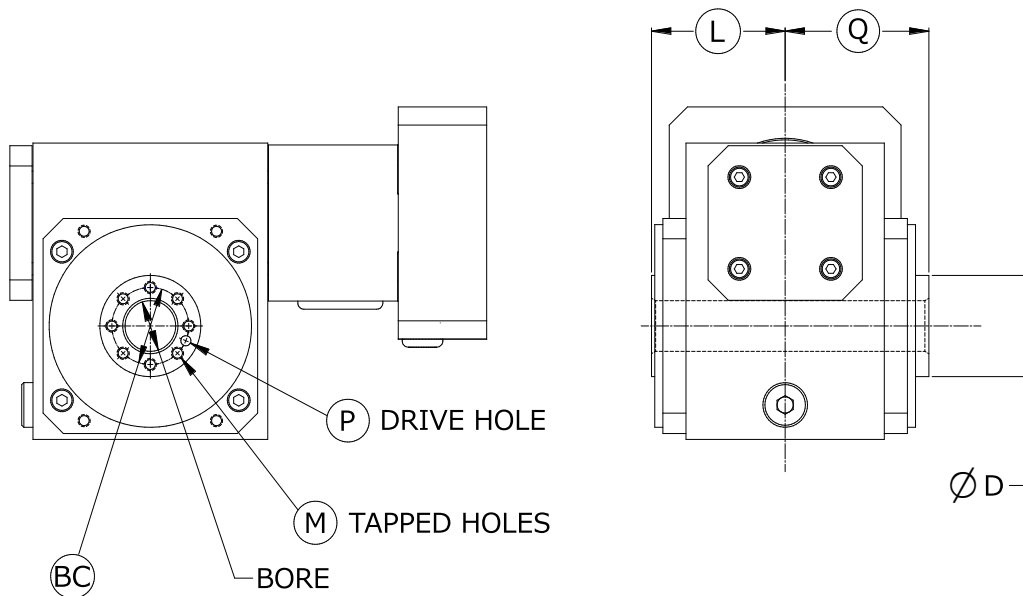

Optional Shaft End Mount

Size	BC	L	M	P	Q	BORE	Ø D
38	28	56	4 x M6 x 1, 12 Deep	5 H9, 10 Deep	61	16 H8	40 h11
51	38	66	8 x M6 x 1, 12 Deep	5 H9, 10 Deep	71	25 H7	50 h11
64	50	74	8 x M8 x 1.25, 16 Deep	6 H9, 10 Deep	79	30 H7	65 h11
76	60	100	8 x M8 x 1.25, 16 Deep	8 H9, 10 Deep	105	35 H7	80 h11
89	70	117	8 x M10 x 1.5, 20 Deep	8 H9, 10 Deep	122	45 H7	90 h11

Series W

Servo Gearhead Expanded Rating Table Size W38

Size W38

Ratio		Worm shaft speed (RPM)											
		500		1000		2000		3000		4000		6000	
		lb. In.	Nm	lb. In.	Nm	lb. In.	Nm	lb. In.	Nm	lb. In.	Nm	lb. In.	Nm
5:1	Output Torque T_{accel}	500	56	460	52	410	46	360	41	310	35	260	29
	Output Torque T_{run}	460	52	410	46	310	35	260	29	220	25	180	20
	Efficiency %	88	88	89	88	88	87	87	87	87	87	87	87
10:1	Output Torque T_{accel}	610	69	560	63	520	59	470	53	410	46	340	38
	Output Torque T_{run}	560	63	520	59	410	46	340	38	290	33	230	26
	Efficiency %	84	84	87	87	86	86	85	85	85	85	85	85
15:1	Output Torque T_{accel}	610	69	570	64	540	61	480	54	430	49	350	40
	Output Torque T_{run}	570	64	540	61	430	49	350	40	300	34	250	28
	Efficiency %	81	81	85	85	84	84	83	83	83	83	83	83
20:1	Output Torque T_{accel}	590	67	570	64	530	60	480	54	420	47	350	40
	Output Torque T_{run}	570	64	530	60	420	47	350	40	300	34	240	27
	Efficiency %	79	79	81	81	81	81	80	80	80	80	80	80
30:1	Output Torque T_{accel}	550	62	520	59	500	56	460	52	410	46	330	37
	Output Torque T_{run}	520	59	500	56	410	46	330	37	290	33	230	26
	Efficiency %	71	71	76	76	76	76	75	75	75	75	75	75
40:1	Output Torque T_{accel}	480	54	480	54	460	52	420	47	370	42	300	34
	Output Torque T_{run}	480	54	460	52	370	42	300	34	260	29	210	24
	Efficiency %	68	68	72	72	72	72	71	71	71	71	71	71
50:1	Output Torque T_{accel}	480	54	480	54	460	52	410	46	370	42	300	34
	Output Torque T_{run}	480	54	460	52	370	42	300	34	260	29	210	24
	Efficiency %	65	65	69	69	69	69	68	68	68	68	68	68
60:1	Output Torque T_{accel}	450	51	450	51	420	47	380	43	340	38	280	32
	Output Torque T_{run}	450	51	420	47	340	38	280	32	240	27	200	23
	Efficiency %	62	62	66	66	66	66	65	65	65	65	65	65

Servo Gearhead Expanded Rating Table Size W51

Size W51

Ratio		Worm shaft speed (RPM)											
		500		1000		2000		3000		4000		6000	
		lb. In.	Nm	lb. In.	Nm	lb. In.	Nm	lb. In.	Nm	lb. In.	Nm	lb. In.	Nm
5:1	Output Torque T_{accel}	1010	110	930	110	800	90	680	77	590	67	480	54
	Output Torque T_{run}	930	110	800	90	590	67	480	54	410	46	310	35
	Efficiency %	91	91	92	92	92	92	91	91	90	90	89	89
6:1	Output Torque T_{accel}	1100	120	1020	120	880	99	750	85	660	75	540	61
	Output Torque T_{run}	1020	120	880	99	660	75	540	61	450	51	350	40
	Efficiency %	91	91	92	92	91	91	91	91	90	90	89	89
7:1	Output Torque T_{accel}	1150	130	1060	120	930	110	790	89	1060	120	930	110
	Output Torque T_{run}	1060	120	930	110	690	78	570	64	480	54	370	42
	Efficiency %	90	90	91	91	91	91	90	90	89	89	88	88
8:1	Output Torque T_{accel}	1200	140	1110	130	980	110	840	95	730	82	600	68
	Output Torque T_{run}	1110	130	980	110	730	82	600	68	510	58	390	44
	Efficiency %	89	89	91	91	91	91	90	90	89	89	88	88
9:1	Output Torque T_{accel}	1200	140	1130	130	1000	110	860	97	750	85	610	69
	Output Torque T_{run}	1130	130	1000	110	750	85	610	69	520	59	400	45
	Efficiency %	88	88	90	90	90	90	89	89	88	88	87	87
10:1	Output Torque T_{accel}	1220	140	1140	130	1020	120	880	99	770	87	630	71
	Output Torque T_{run}	1140	130	1020	120	770	87	630	71	540	61	410	46
	Efficiency %	87	87	90	90	90	90	89	89	88	88	87	87
15:1	Output Torque T_{accel}	1220	140	1160	130	1060	120	910	103	800	90	660	75
	Output Torque T_{run}	1160	130	1060	120	800	90	660	75	560	63	430	49
	Efficiency %	84	84	88	88	88	88	86	86	86	86	86	86
20:1	Output Torque T_{accel}	1190	130	1140	130	1060	120	900	102	780	88	650	73
	Output Torque T_{run}	1140	130	1060	120	780	88	650	73	550	62	430	49
	Efficiency %	83	83	84	84	85	85	84	84	83	83	82	82
25:1	Output Torque T_{accel}	1160	130	1130	130	1020	120	900	102	790	89	650	73
	Output Torque T_{run}	1130	130	1020	120	790	89	650	73	550	62	430	49
	Efficiency %	81	81	84	84	84	84	83	83	82	82	81	81
30:1	Output Torque T_{accel}	1110	130	1060	120	990	110	860	97	760	86	620	70
	Output Torque T_{run}	1060	120	990	110	760	86	620	70	530	60	410	46
	Efficiency %	75	75	80	80	80	80	79	79	78	78	77	77
40:1	Output Torque T_{accel}	1010	110	1010	110	940	110	820	93	720	81	590	67
	Output Torque T_{run}	1010	110	940	110	720	81	590	67	500	56	390	44
	Efficiency %	72	72	74	74	76	76	75	75	74	74	73	73
50:1	Output Torque T_{accel}	970	110	970	110	910	100	790	89	690	78	570	64
	Output Torque T_{run}	970	110	910	100	690	78	570	64	490	55	380	43
	Efficiency %	68	68	72	72	73	73	71	71	69	69	67	67
60:1	Output Torque T_{accel}	930	110	930	110	870	100	760	86	660	75	550	62
	Output Torque T_{run}	930	110	870	100	660	75	550	62	460	52	360	41
	Efficiency %	65	65	70	70	70	70	69	69	67	67	68	68

Series W

Servo Gearhead Expanded Rating Table

Size W64

Size W64

Ratio		Worm shaft speed (RPM)											
		500		1000		2000		3000		4000		6000	
		lb. In.	Nm	lb. In.	Nm	lb. In.	Nm	lb. In.	Nm	lb. In.	Nm	lb. In.	Nm
5:1	Output Torque T_{accel}	1980	220	1800	200	1470	170	1220	140	1060	120	850	100
	Output Torque T_{run}	1800	200	1470	170	1060	120	850	100	700	79	540	61
	Efficiency %	91	91	92	92	92	92	91	91	90	90	89	89
6:1	Output Torque T_{accel}	2160	240	1970	220	1630	180	1350	150	1180	130	950	110
	Output Torque T_{run}	1970	240	1970	220	1630	180	1350	150	1180	130	950	110
	Efficiency %	91	91	92	92	92	92	91	91	90	90	89	89
7:1	Output Torque T_{accel}	2240	250	2050	230	1720	190	1420	160	1240	140	1000	110
	Output Torque T_{run}	2050	230	1720	190	1240	140	1000	110	830	94	640	72
	Efficiency %	90	90	91	91	91	91	90	90	89	89	88	88
8:1	Output Torque T_{accel}	2340	260	2150	240	1820	140	1000	110	830	94	640	72
	Output Torque T_{run}	2150	240	1820	210	1310	150	1060	120	890	100	680	77
	Efficiency %	89	89	91	91	91	91	90	90	89	89	88	88
9:1	Output Torque T_{accel}	2350	270	2170	250	1850	210	1540	170	1340	150	1090	120
	Output Torque T_{run}	2170	250	1850	210	1340	150	1090	120	910	100	690	78
	Efficiency %	88	88	90	90	90	90	89	89	88	88	87	87
10:1	Output Torque T_{accel}	2380	270	2210	250	1900	210	1580	180	1370	150	1110	130
	Output Torque T_{run}	2210	250	1900	210	1370	150	1110	130	930	110	710	80
	Efficiency %	87	87	90	90	90	90	89	89	88	88	87	87
15:1	Output Torque T_{accel}	2390	270	2250	250	1960	220	1640	130	970	110	740	84
	Output Torque T_{run}	2250	250	1960	220	1430	160	1160	130	970	110	740	84
	Efficiency %	85	85	88	88	88	88	87	87	86	86	85	85
20:1	Output Torque T_{accel}	2320	260	2230	250	1920	220	1620	180	1410	160	1150	130
	Output Torque T_{run}	2230	250	1920	220	1410	160	1150	130	970	110	740	84
	Efficiency %	83	83	84	84	85	85	84	84	83	83	82	82
25:1	Output Torque T_{accel}	2270	260	2210	250	1920	220	1620	180	1400	160	1140	130
	Output Torque T_{run}	2210	250	1920	220	1400	160	1140	130	960	110	740	84
	Efficiency %	81	81	84	84	84	84	83	83	82	82	81	81
30:1	Output Torque T_{accel}	2170	250	2060	230	1840	210	1550	180	1350	150	1100	120
	Output Torque T_{run}	2060	230	1840	210	1350	150	1100	120	920	100	710	80
	Efficiency %	75	75	80	80	80	80	79	79	78	78	77	77
40:1	Output Torque T_{accel}	1970	220	1960	220	1750	200	1480	170	1290	150	1040	120
	Output Torque T_{run}	1960	220	1750	200	1290	150	1040	120	880	99	670	76
	Efficiency %	72	72	74	74	76	76	75	75	74	74	73	73
50:1	Output Torque T_{accel}	1900	210	1900	190	1240	140	1010	110	850	96	650	73
	Output Torque T_{run}	69	69	72	72	73	73	71	71	69	69	67	67
	Efficiency %	69	69	72	72	73	73	71	71	69	69	67	67
60:1	Output Torque T_{accel}	1810	200	1810	200	1620	180	1370	150	1190	130	970	110
	Output Torque T_{run}	1810	200	1620	180	1190	130	970	110	810	92	620	70
	Efficiency %	65	65	70	70	70	70	69	69	68	68	67	67

Servo Gearhead Expanded Rating Table Size W76

Size W76

Ratio		Worm shaft speed (RPM)											
		500		1000		2000		3000		4000		6000	
		lb. In.	Nm	lb. In.	Nm	lb. In.	Nm	lb. In.	Nm	lb. In.	Nm	lb. In.	Nm
5:1	Output Torque T_{accel}	3500	400	3110	350	2430	270	2010	230	1740	200	1360	150
	Output Torque T_{run}	3110	350	2430	270	1740	200	1360	150	1110	130	860	100
	Efficiency %	91	91	92	92	92	92	91	91	90	90	89	89
6:1	Output Torque T_{accel}	3820	430	3420	390	2710	310	2240	250	1940	220	1530	170
	Output Torque T_{run}	3420	390	2710	310	1940	220	1530	170	1250	140	960	110
	Efficiency %	91	91	92	92	92	92	91	91	90	90	89	89
7:1	Output Torque T_{accel}	3960	450	3580	400	2870	320	2370	270	2060	230	1630	180
	Output Torque T_{run}	3580	400	2870	320	2060	230	2370	270	1330	150	1030	120
	Efficiency %	90	90	91	91	91	91	90	90	89	89	88	88
8:1	Output Torque T_{accel}	4140	3760	420	3050	340	2530	290	2200	250	1740	200	68
	Output Torque T_{run}	3760	420	3050	340	2200	250	1740	200	1430	160	1100	120
	Efficiency %	89	89	91	91	91	91	90	90	89	89	88	88
9:1	Output Torque T_{accel}	4170	470	3810	430	3140	350	2600	290	2260	260	1800	200
	Output Torque T_{run}	3810	430	3140	350	2260	260	1800	200	1480	260	1800	200
	Efficiency %	88	88	90	90	90	90	89	89	88	88	87	87
10:1	Output Torque T_{accel}	4230	480	3890	440	3240	370	2680	300	2340	260	1870	210
	Output Torque T_{run}	3890	440	3240	370	2340	260	1870	210	1530	170	1180	130
	Efficiency %	87	87	90	90	89	89	89	89	88	88	87	87
15:1	Output Torque T_{accel}	4250	480	3980	450	3370	380	2790	320	2430	270	1940	220
	Output Torque T_{run}	3980	450	3370	380	2430	270	1950	220	1610	180	1240	140
	Efficiency %	85	85	88	88	88	88	87	87	86	86	85	85
20:1	Output Torque T_{accel}	4130	470	3940	450	3300	370	2770	310	2410	270	1940	220
	Output Torque T_{run}	3940	450	3300	370	2410	270	1940	220	1600	180	1230	140
	Efficiency %	83	83	84	84	85	85	84	84	83	83	82	82
25:1	Output Torque T_{accel}	4050	460	3900	4400	3300	370	2760	310	2400	270	1930	220
	Output Torque T_{run}	3900	440	3300	370	2400	270	1930	220	1600	180	1230	140
	Efficiency %	81	81	84	84	84	84	83	83	82	82	81	81
30:1	Output Torque T_{accel}	3860	440	3630	410	3160	360	2640	300	2300	260	2850	210
	Output Torque T_{run}	3630	410	3160	360	2300	260	1850	210	1530	170	1180	130
	Efficiency %	75	75	80	80	80	80	79	79	78	78	77	77
40:1	Output Torque T_{accel}	3510	400	3470	390	3020	340	2520	280	2200	250	1760	200
	Output Torque T_{run}	3470	390	3020	340	2200	250	1760	200	1460	160	1120	130
	Efficiency %	71	71	74	74	76	76	75	75	74	74	73	73
50:1	Output Torque T_{accel}	3390	380	3350	380	2910	330	2430	270	2120	240	1700	190
	Output Torque T_{run}	3350	380	2910	330	2120	240	1700	190	1410	160	1080	120
	Efficiency %	68	68	72	72	73	73	71	71	69	69	67	67
60:1	Output Torque T_{accel}	3230	360	3190	360	2790	320	2330	260	2030	230	1630	180
	Output Torque T_{run}	3190	360	2790	320	2030	230	1630	180	1350	150	1040	120
	Efficiency %	65	65	70	70	70	70	69	69	68	68	67	67

Series W

Servo Gearhead Expanded Rating Table

Size W89

Size W89

Ratio		Worm shaft speed (RPM)											
		500		1000		2000		3000		4000		6000	
		lb. In.	Nm	lb. In.	Nm	lb. In.	Nm	lb. In.	Nm	lb. In.	Nm	lb. In.	Nm
5:1	Output Torque T_{accel}	6450	730	5610	630	4250	480	3520	400	3010	340	2300	260
	Output Torque T_{run}	5610	630	4250	480	3010	340	2300	260	1900	210	1450	160
	Efficiency %	91	91	92	92	91	91	90	90	90	90	90	90
6:1	Output Torque T_{accel}	7040	800	6190	700	4750	540	3930	440	3380	380	2580	290
	Output Torque T_{run}	6190	700	4750	540	3380	380	2580	290	2140	240	1640	190
	Efficiency %	90	90	92	92	91	91	90	90	90	90	90	90
7:1	Output Torque T_{accel}	7320	830	6480	730	5030	570	4160	470	3580	400	2740	310
	Output Torque T_{run}	6480	730	5030	570	3580	400	2740	310	2270	260	1740	200
	Efficiency %	89	89	91	91	91	91	90	90	89	89	88	88
8:1	Output Torque T_{accel}	7640	860	6810	770	5340	600	4420	500	3810	430	2950	330
	Output Torque T_{run}	6810	770	5340	600	3810	430	2950	330	2430	270	1860	210
	Efficiency %	89	89	91	91	90	90	89	89	89	89	89	89
9:1	Output Torque T_{accel}	7700	870	6900	780	5480	620	4530	510	3910	440	3050	340
	Output Torque T_{run}	6900	780	5480	620	3910	440	3050	340	2500	280	1910	220
	Efficiency %	88	88	90	90	90	90	89	89	88	88	88	88
10:1	Output Torque T_{accel}	7800	880	7040	800	5650	640	4650	530	4030	460	3170	360
	Output Torque T_{run}	7040	800	5650	640	4030	460	3170	360	2700	310	2090	240
	Efficiency %	87	87	90	90	89	89	88	88	88	88	88	88
15:1	Output Torque T_{accel}	7820	880	7210	810	5870	660	4850	550	4210	480	3310	370
	Output Torque T_{run}	7210	810	5870	660	4210	480	3310	370	2700	310	2090	240
	Efficiency %	84	84	88	88	87	87	86	86	86	86	86	86
20:1	Output Torque T_{accel}	7590	860	7150	810	5740	650	4800	540	4170	470	3280	370
	Output Torque T_{run}	7150	810	5740	650	4170	470	3280	370	2680	300	2070	230
	Efficiency %	82	82	84	84	84	84	83	83	83	83	83	83
25:1	Output Torque T_{accel}	7450	840	7080	800	5740	650	4790	540	4150	470	3270	370
	Output Torque T_{run}	7080	800	5740	650	4150	470	3270	370	2680	300	2070	230
	Efficiency %	80	80	83	83	83	83	82	82	82	82	82	82
30:1	Output Torque T_{accel}	7100	800	6590	740	5510	620	4590	520	3980	450	3130	350
	Output Torque T_{run}	6590	740	5510	620	3980	450	3130	350	2560	290	1980	220
	Efficiency %	74	74	79	79	79	79	78	78	78	78	78	78
40:1	Output Torque T_{accel}	6450	730	6290	710	5250	590	4370	490	3800	430	2990	340
	Output Torque T_{run}	6290	710	5250	590	3800	430	2990	340	2440	280	1890	210
	Efficiency %	71	71	71	71	75	75	74	74	74	74	74	74
50:1	Output Torque T_{accel}	6240	710	6080	690	5060	570	4210	480	3660	410	2880	330
	Output Torque T_{run}	6080	690	5060	570	3660	410	2880	330	2350	270	1820	210
	Efficiency %	68	68	72	72	72	72	71	71	71	71	71	71
60:1	Output Torque T_{accel}	5940	670	5780	650	4850	550	4050	460	3510	400	2760	310
	Output Torque T_{run}	5780	650	4850	550	3510	400	2760	310	2260	260	1740	200
	Efficiency %	65	65	69	69	69	69	68	68	68	68	68	68

INSTALLATION, OPERATION & MAINTENANCE INSTRUCTIONS FOR SERIES W RIGHT GEARHEAD

Lubrication

Series W Servo Gearheads are factory filled with Mobil SHC634 synthetic lubricant. They require no lubrication service throughout the life of the unit. Series W Servo Gearheads are built for universal mounting, ready to mount in any position.

Installation

Motor on Gearhead:

1. Clean motor shaft and mating surfaces of the motor and gearhead to ensure they are dust free.
2. Slide the motor shaft into the coupling clamp ring until the gearhead and motor flanges are seated together.
3. Tighten the clamp ring screw through the access slot in the gearhead flange to the following torque settings:

	Unit Size				
	W38	W51	W64	W76	W89
lb. in.	90	90	160	160	350
Nm.	10	10	18	18	40

4. Replace the urethane plug in the access slot.

Hollow Shaft Units:

1. Place key in driven shaft.
2. Slide hollow shaft unit onto the driven shaft.
3. Secure unit to machine base using either a mounting base or torque arm.

Solid Shaft Units:

1. The gearhead must be securely mounted to a rigid flat foundation or base plate. If necessary, shim under the gearhead to provide a flat mounting surface.
2. Four mounting bolts are required to mount all gearheads. If the gearhead will be subjected to heavy overhung load or thrust loading, heat treated mounting bolts must be used to prevent stretching and loosening of the bolts.
3. The output shaft of the gearhead should be coupled to the driven shaft with a flexible coupling and the gearhead aligned with the shaft, within +/- .001". Solid or rigid couplings should be avoided. Failure to properly align shafts and the use of solid couplings can result in excessive coupling and bearing wear, shaft deflection and eventual failure of one or more of the components.

Ancillary Components:

1. Couplings, sheaves and sprockets should be mounted on the reducer shafts carefully. Do not pound or hammer them onto the shafts as this will damage bearings and oil seals.
2. Sprockets and sheaves should be mounted as close to the gearhead as possible and "V" belts and chains adjusted to the proper tension to keep bearing loading and shaft deflection to a minimum. Too much tension in

belts and improper location of sheaves and sprockets will lead to excessive overhung load, bearing wear and shaft deflection. For specific information on overhung load capacity, shaft stress and bearing life, please contact Cone Drive.

Start-Up

1. After the gearhead has been properly mounted and aligned, it is ready for start-up.
2. Make sure driven machine is clear of all obstructions and all safety guards and covers are in place. If possible, turn motor shaft by hand to confirm drive system is operating freely and in correct direction of rotation.
3. Jog motor to confirm proper rotation.
4. Operate gearhead with minimum load for approximately 15 minutes (in both directions if applicable) to seal gears, bearings, and oil seals.

Operation

1. All gearheads require a "run-in" period under load to achieve optimum efficiency. During this initial run-in the gearhead will probably run warmer than normal and draw more current than after the run-in period. Gearheads operating at a very low load or speed will take much longer to run-in and even if operated continuously at low load or speed may never achieve the efficiency that they would if operated at or near their catalog rating.
2. IMPORTANT: Normal gearhead operating temperature measured at the oil sump area of the housing should not exceed 100°F above ambient temperature or 210°F maximum. If the gearhead operating temperature exceeds these limits, shut down the unit and contact Cone Drive. Excessive oil sump temperature is indicative of overloading, misalignment, or improper or marginal lubrication. Continuous operation of the gearhead with the oil sump temperature above will result in failure of the gearhead.

Maintenance

1. If a gearhead has to be repaired, contact Cone Drive for detailed instruction, blueprints, parts lists, etc. If necessary, field service is available.
2. If a gearhead is to be returned, contact Cone Drive for instructions and a returned material authorization (RMA) number.
3. Please have model number information from the unit name plate recorded.

Call Parts & Service Toll Free 888-726-2663

Notes



Cone Drive Operations, Inc.

240 East 12th Street
Traverse City, Michigan 49684
USA

Cone Drive Operations, Ltd.

1 Redwood Crescent, Peel Park
East Kilbride G74 5PA
UK

H-Fang

A Cone Drive Company
No. 20 Yungu Road
Changshou
Zhouzhuang Town, Jiangyin
Jiangsu PR China 214424