

# STAINLESS REDUCER

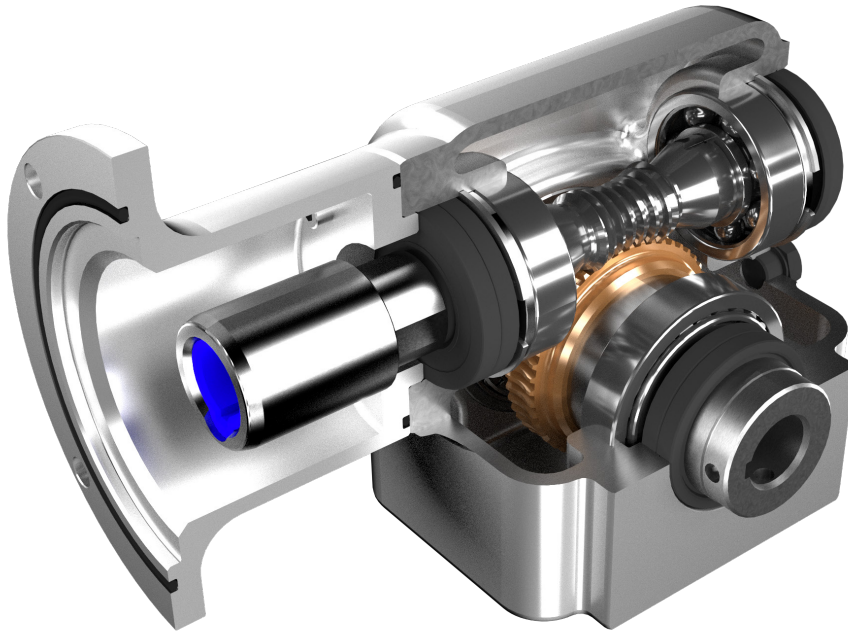

Cone Drive's stainless steel reducers are designed for sterile manufacturing environments. The smooth housings allow for easy cleaning and bacteria free surfaces.



FEATURES

- PROTECTION TYPE IP69K
- LIFE-TIME LUBRICATION WITH FOOD-GRADE OIL
- DOUBLE-ENVELOPING WORM GEARING

- INCH OR METRIC SHAFTS
- DOUBLE SEAL INPUT & OUTPUT SEALS
- ASEPTIC DESIGN
- NON-FRETTING MOTOR CONNECTION

SPECS

CENTER DISTANCES  
 NEMA FRAMES  
 OUTPUT TORQUE  
 GEAR RATIOS  
 OUTPUT OPTIONS  
 MATERIAL

1.54", 1.75", 1.97", 2.38", 3.00"  
 Up to 184TC frame  
 Up to 6,660 lb-in  
 From 5:1 to 60:1, single reduction  
 Solid or Hollow Shaft in inch or metric sizes  
 316 Stainless Steel